

EQUAL Mechanical Disc Brake Caliper User's Manual

Important Notice

Do not install the parts if you are not an expert on bicycles. If you are not sure about the work, ask a professional store to do the work.

If you have any questions about the contents of this manual, please do not attempt to install the parts. If you have any questions about the contents of this manual, please contact the dealer where you purchased the product or mail to GROWTAC(wininfo@growtac.com).

GROWTAC is not responsible for any damage or injury caused by accidents that occur during use it other than defects in the product. (This includes incorrect installation, lack of maintenance, etc.)

Concept & data regarding the design and features of this product are available on our website. We recommend that you read this information before using the product.

Dealer manuals for dealers and other people with expertise in bicycles are available on our website.

For your safety, please read this user's manual carefully before installing and using the product.

Caution / Warning

Warnings

When installing the product, be sure to follow the instructions in the user's manual.

It is recommended to use genuine EQUAL products for the mounting bolts, brake pads and other consumables. If the brakes are not adjusted correctly, they may not work and serious injury may result from a serious accident.

The calipers and disc brake rotors will become hot when the brakes are operated. Do not touch them while riding or immediately after riding a bicycle. Otherwise, you may get burned.

Do not allow grease or other oil to get on the rotor or brake pads. If grease or oil gets on the rotor or brake pads, the brakes will not work, which is extremely dangerous. Ask your dealer what to do if grease or oil gets on the brake pads.

Before riding, be sure to check that the thickness of the brake pads is at least 0.5 mm. If the pads are worn out beyond this point, the brakes may not work.

If the pads are worn out, replace them with new brake pads referring to "6-1 Replacing the brake pads".

Standard brake pads: EQUAL disc brake pads DBR-PADA01 (Shimano road compatible).

When the brake pads are worn out, adjust the clearance with reference to "5-1 Adjusting the brake pad clearance". If the brake pads continue to be used without adjustment, the brakes may become ineffective.

Before riding, make sure that the brake cable is not frayed. If there are any loose ends, the brake cable may break and the brake will not work.

If the front brake is applied too hard, the front wheel may lock, causing the bicycle to fall forward and cause serious injury.

The braking distance becomes longer in rainy weather. In wet condition, the braking distance is longer, so reduce speed and brake earlier.

If you brake suddenly when the road surface is wet, the tires may slip and you may fall over. When the road surface is wet, braking suddenly may cause the tires to slip, resulting in a fall.

Make sure that the pin does not enter the danger zone of the swing arm when the brake is applied. If the pin enters the "Danger Zone", replace the brake pad or adjust the clearance.

Make sure that the brake pad mounting screws are properly tightened.

Cautions

When the brake pads or rotors are replaced with new ones, the brakes will be less effective.

Please test it quite few times in a safe place and in safe speed.

When the brake is applied, a braking sound may be heard.

If you have any questions about installation or adjustment, please contact your dealer or mail to GROWTAC (winfo@growthac.com). We will reply to you within 3 business days.

1 List of specification parts (Component parts list)

Disc brake caliper (per caliper body)

- 1 pc Disc caliper body
- 2 pcs Disc brake pads (built into the body)
- 2 pcs Disc brake pads (built in)
- 1 pc Pad retaining spring (built in)
- 1 pc Brake pad mounting screw
- 1 pc cap for pad adjustment hole

Cable set for drop handlebar (per caliper body)

- 1 pc Hard outer casing (1700mm)
- 1 pc Soft outer casing (1000mm)
- 1 pc Slick inner cable for drop handlebar lever (1900mm SHIMANO road lever compatible)
- 2 pcs Outer casing connector (5.0mm-5.5mm)
- 1 pc Outer casing cap for caliper
- 2 pcs Outer casing cap 5mm
- 1 pcs Inner cable cap

Cable set for flat handlebar (per caliper body)

- 1 pc Hard outer casing (1700mm)
- 1 pc Soft outer casing (1000mm)
- 1 pc Slick inner cable for flat handlebar lever (1900mm)
- 1 pc Outer casing cap for flat handlebar lever
- 2 pcs Outer casing connector (5.0mm-5.5mm)
- 1 pc Outer casing cap for caliper
- 2 pcs Outer casing cap 5mm
- 1 pc Inner cable cap

Adapter set for flat mount (Front, 140mm/160mm)

- 1 pc Adapter for flat mount (front, 140mm/160mm)
- 2 pcs Front caliper fixing bolts (silver)
- 2 pcs Frame fixing bolts (black)

Mounting bolt set for flat mount (Rear)

- Each 2 pcs Rear caliper fixing bolt (20mm/25mm/30mm/35mm/40mm/45mm)
- 2 pcs Rear caliper fixing washers

2 List of Tools used

- Hex keys 2.5mm/3mm/4mm
- Torx wrench T25
- Wire cutter

3 Caliper main body part names

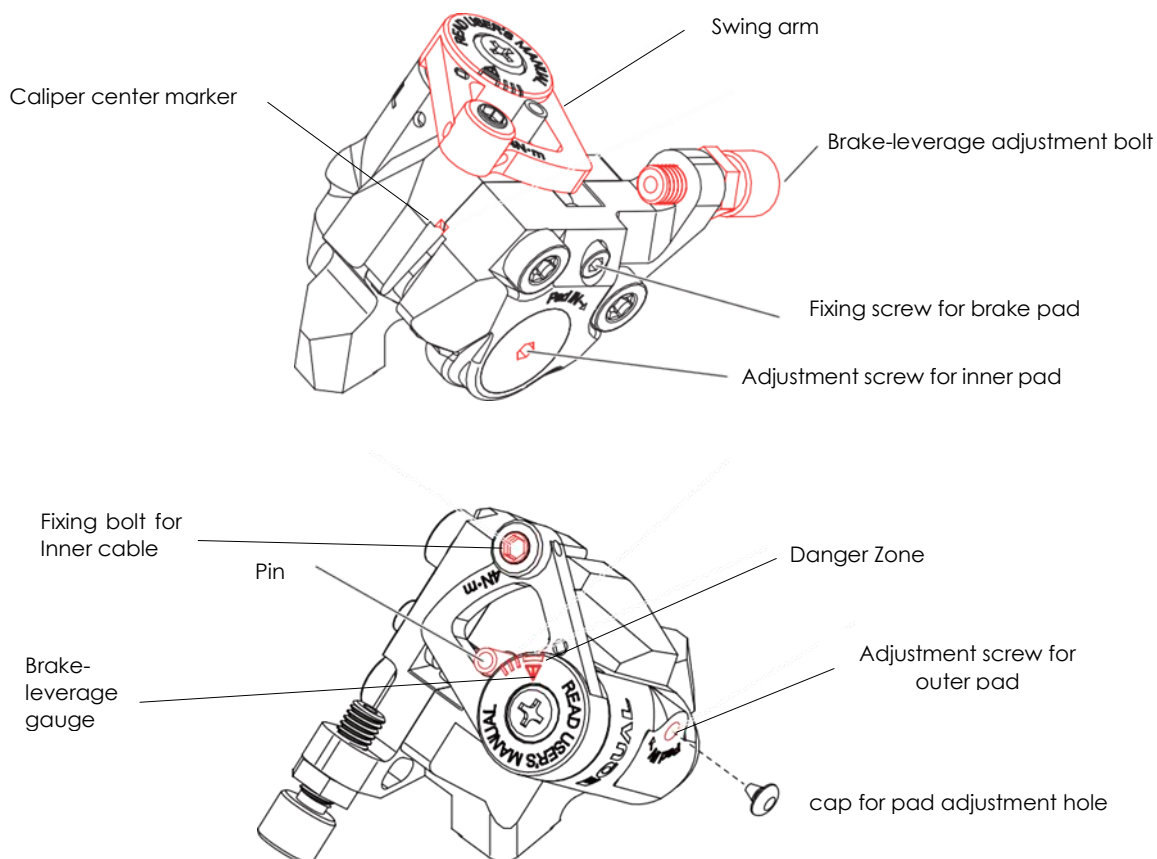

4. Installation procedure

4-1. Initial position setting of the brake-leverage adjustment bolt

Adjust the gap of the brake-leverage adjustment bolt so that it is 1~2mm.

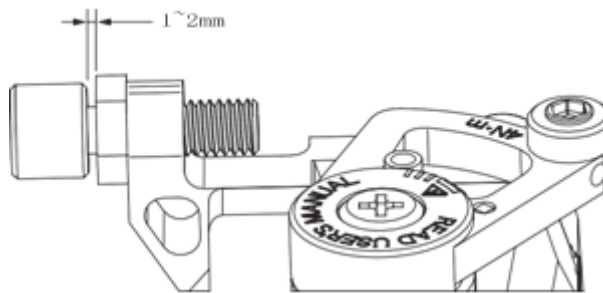

4-2. Temporarily fasten the caliper

Front caliper

After adjusting the direction of the front adapter to match the rotor size to be used, secure the brake caliper and front adapter with the Front caliper fixing bolt. (T25 Torx wrench, specified torque 6 Nm).

Attach the adapter to the brake caliper. Temporarily fix the adapter to the frame with the frame fixing bolts, lightly enough to allow it to move left and right (4mm hex key).

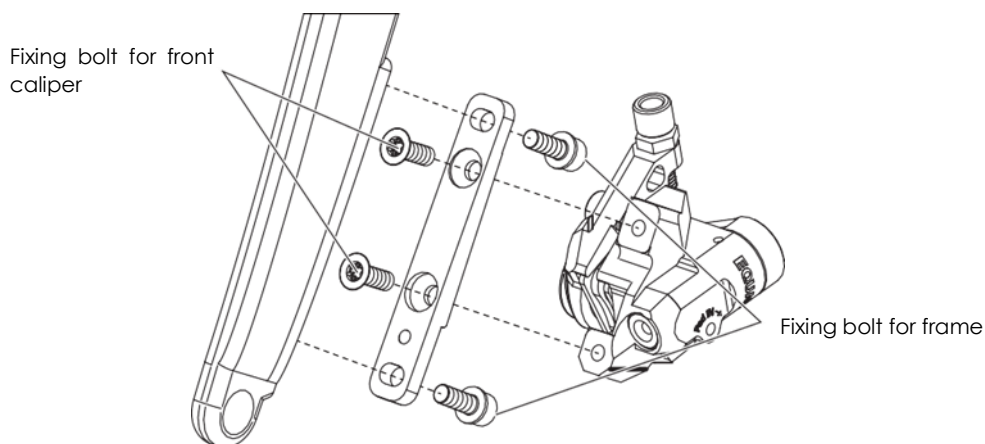

Rear caliper

When using a 140mm rotor

Insert the rear caliper fixing bolt with washer into the caliper mounting hole on the frame and use a bolt that is long enough to protrude about 7~11mm. Insert the Rear caliper fixing bolt with washer into the caliper mounting hole.

As with the front, temporarily fix the caliper to the frame with enough force to allow it to move left and right (4mm hex key).

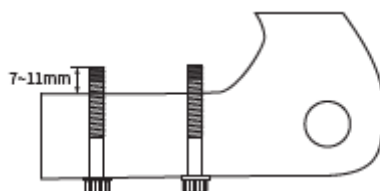

When using a rotor larger than 140mm

Prepare an adapter from third party and install it according to the instructions of the adapter.

4-3. Outer casing installation

This product provides high braking power by using a combination of two types of outer casings designed specifically for this product.

Soft outer casing

This is a flexible outer casing that is used for areas with tight bends such as around the handlebar, or where handling may be adversely affected.

Hard outer casing

This is a casing with high rigidity. This type of casing is mainly used to improve braking power. This casing is mainly used to improve the braking force.

* If the hard outer casing is not used, the original braking force may not be achieved.

Setting Example

At Handlebar Area

✧ Using Soft outer casing for Drop handlebar

Use the soft outer casing for areas with tight bends.

Use a hard outer casing for the part where the wiring is straight.

*If you want to put the outer connector inside the frame, you must have a hole of 6.6mm or more.

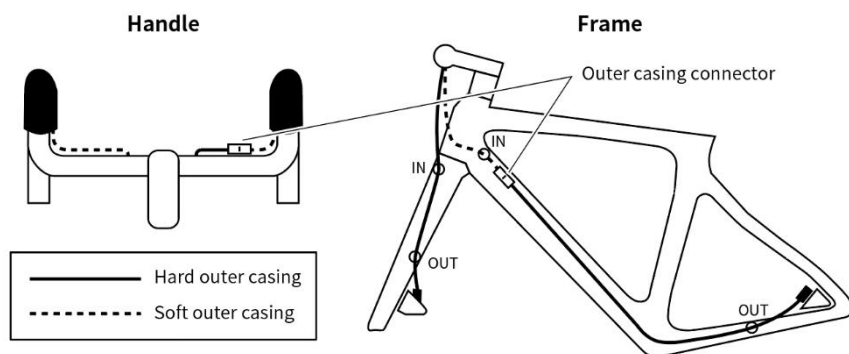

✧ Using Hard outer casing for Flat handlebar

Attach the outer cap for the lever to the brake lever and install the hard outer casing.

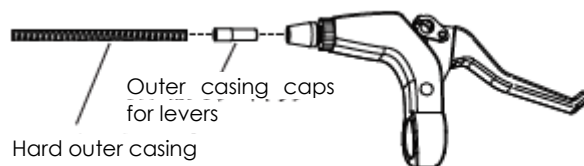

For flat handlebars, it is recommended to use only the hard outer casing, but if the rebound is too strong and you see bad effects on your handling, use the soft outer casing as well as the drop handlebars.

At Caliper area

Cut the outer casing to the appropriate length, install the outer casing cap for the caliper, and connect it to the caliper body.

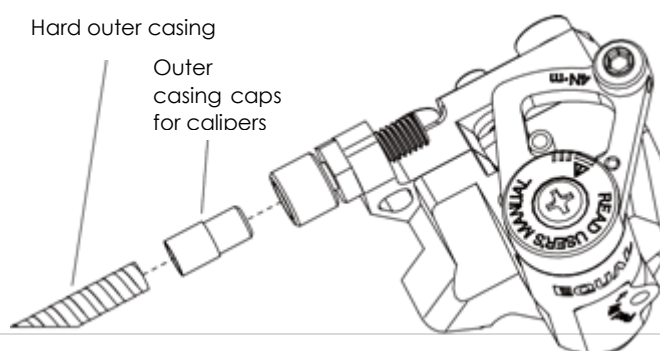

4-4 Installing the inner cable

Loosen the inner cable fixing bolt on the swing arm sufficiently to allow the inner cable to pass through. Pass the inner cable through while pushing the swing arm fully in the left rotation direction. After the inner cable is passed through, move the swing arm back, pull the inner cable, and then secure it once with the inner cable fixing bolt (3mm hex key, specified torque 4Nm).

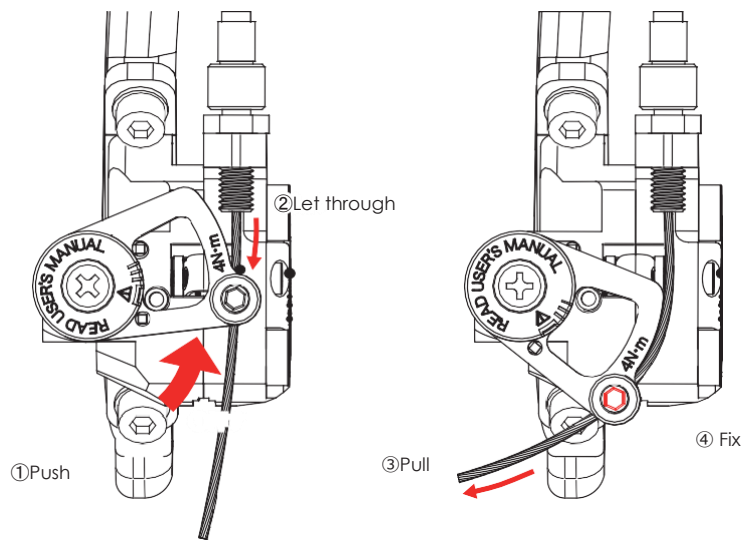

4-5. Fixing the caliper (centering)

Turn the left and right brake pad adjustment screws and push both pads out until the rotor is fixed (3mm hex key). Pinch the rotor between both pads so that the caliper center marker and the center of the rotor are on the same line.

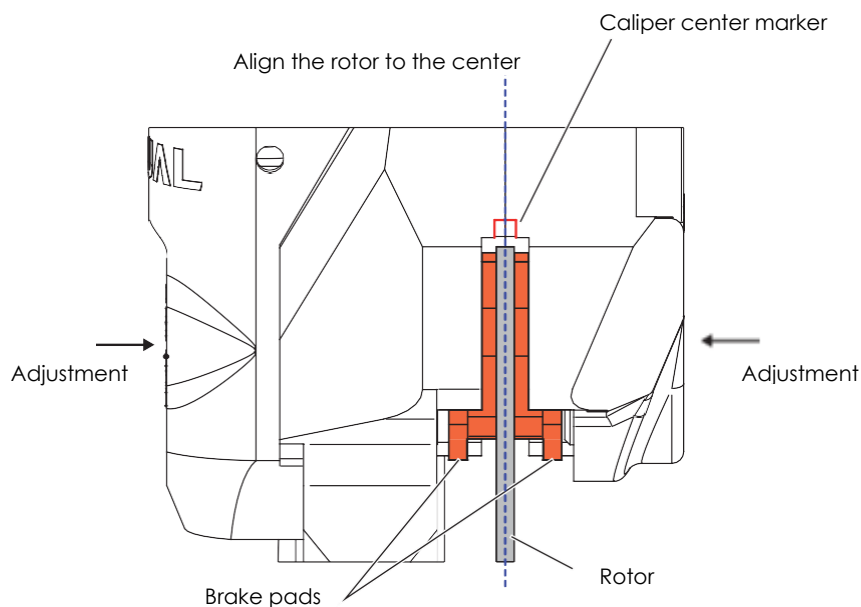

To operate the pad adjustment screw, refer to "5-1 Adjusting the brake pad clearance".

When the center of the rotor and caliper are aligned, tighten the temporarily fastened caliper fixing bolts to the frame you are using with the appropriate torque.

⚠ Caution: Do not operate the pad adjustment screw without brake pads. Otherwise, the internal parts may come off.

4-6 Accustoming the cable

Squeeze the brake strongly about 10 times to break in the cable.

4-7. Fixing the inner cable

Loosen the inner cable fixing bolt once, pull the inner cable to remove any slack in the wire, and secure it again with the inner cable fixing bolt (3mm hex key, specified torque 4Nm). Cut off the inner cable leaving about 20 mm of its allowance, and install the inner cable cap.

4-8 Adjusting the brake pads

Turn both brake pads adjustment screws to the left direction to increase the clearance between the rotor and brake pads. After widening, refer to "5-1 Adjusting the brake pad clearance" to adjust the clearance appropriately.

4-9. Adjusting the brake pads

After replacing the brake pads or rotors, the braking effect will be weakened until they are acclimated. Repeat stopping from a safe speed in a safe place, and start using the brakes only after the brakes are sufficiently effective.

5. Adjustment

5-1. Brake Pad Clearance Adjustment

It is necessary to adjust the clearance of the brake pads in the following cases.

- ✓ Immediately after installing the brake caliper.
- ✓ After brake pad replacement
- ✓ When the brake pads are worn out.
- ✓ If the clearance is not adjusted,

If you do not adjust, brake may not work even if you hold a brake lever, which is extremely dangerous. When adjusting the clearance, adjust both the outside and the inside.

Use a 3mm hex key to adjust the pads. Turning the pad adjustment screw to the right (clockwise) will narrow the clearance between the rotor and pad, and turning it to the left (counterclockwise) will widen the clearance.

Caution: Do not operate the pad adjustment screw without brake pads.

Otherwise, the internal parts may come off.

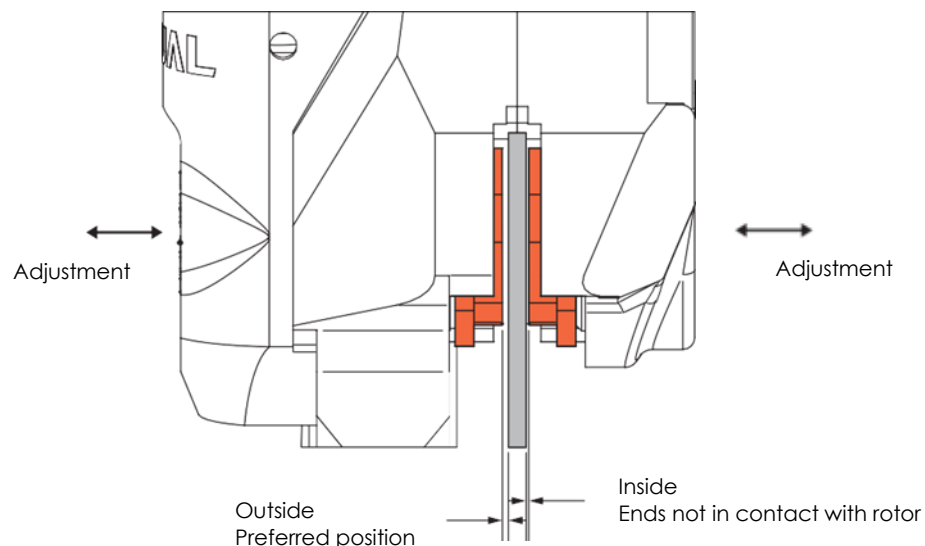

Adjustment Procedure

1 Adjust the inner pads

Adjust the clearance between the brake pads and the rotor to the point where no contact noise is heard when the wheel rotates.

[Tips]

After narrowing the brake pad until it makes contact with the rotor, turn the pad adjustment screw to the left while turning the wheel, and then turn it back until there is no contact sound with the rotor.

2 Outside pad adjustment

While operating the brake lever, adjust the pad position to achieve the desired amount of pull.

3 Checking the brakes

Grip the brake lever and check that the brake is applied correctly.

5-2. Adjusting the Brake-Leverage

This has a function to adjust the braking force. Hence, you can make adjustments according to your comfortable braking.

It is recommended that you use the default settings at first, and then optimize them with your favorite settings.

After "5-1. Adjusting the brake pad clearance", lightly depress the lever, and when the pad touches the rotor, the position of the brake-leverage gauge indicated by the pin will be the reference position.

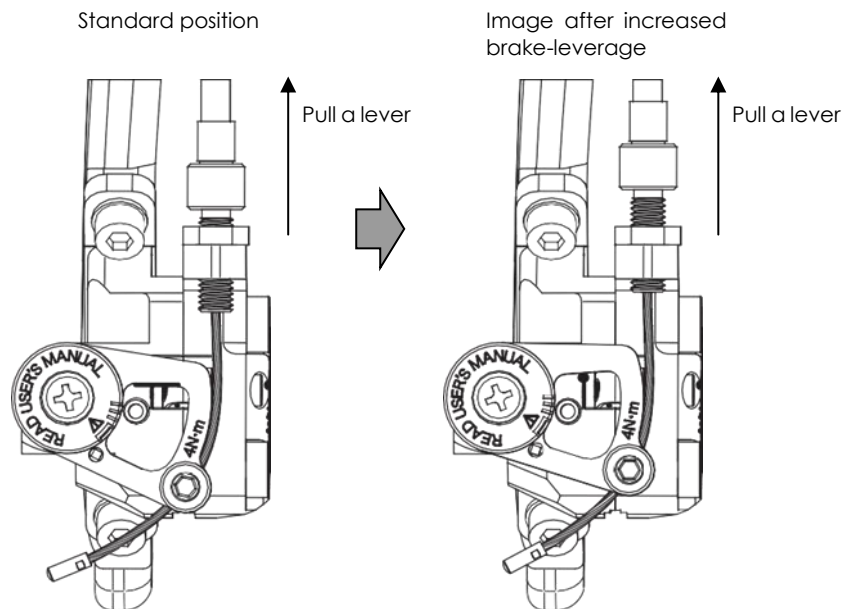

On the Left is the default setting image. On the right is the setting image with the brake-leverage is highly adjusted. The default setting depends on the adjustment of the brake pad clearance.

Adjustment Procedure

1 Release the outer pad from the rotor.

Turn the outer pad adjustment screw to the left to increase the clearance between the rotor and pad.

2 Adjusting the brake-leverage

When the brake-leverage adjustment bolt is turned to the left, the swing arm will move in conjunction with it in the direction of left rotation. Adjust using the brake-leverage gauge and pin marked on the inside of the swing arm as a guide.

3 Adjusting the clearance of the outer pad

With reference to "5-1 Adjusting the brake pad clearance", turn the pad adjustment screw on the outside of the bike to the right to adjust the clearance.

4 Confirmation by actual riding

Check the "brake-leverage" by actual riding. If the feeling is not to your liking, perform steps 1 to 3 again to make adjustments.

[Tips]

The tip to adjusting the brake-leverage is to first adjust the scale significantly and then try to feel the difference in braking force between each. After that, make fine adjustments.

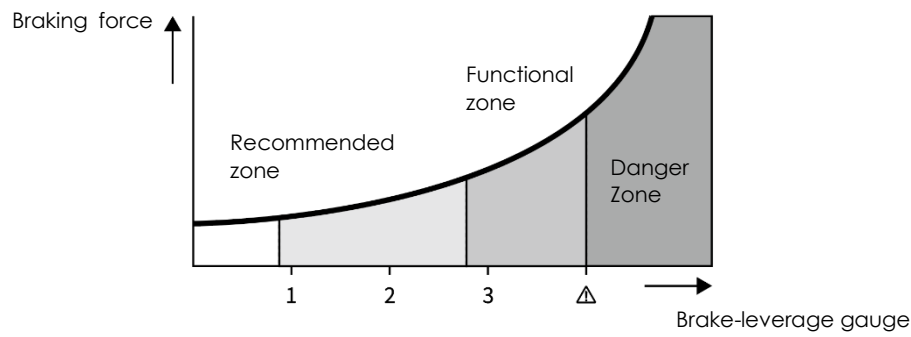

⚠ CAUTION

Adjust the brake-leverage so that the pin does not enter the Danger Zone when the brake lever is depressed. Brakes may not work if the pin enters the "Danger Zone", which is very dangerous. Be sure to check the position of the feeling gauge before riding, and if you feel any discomfort in the braking while riding, check the position of the brake-leverage gauge and adjust it as necessary.

Always check the gauge position not for pin to point "Danger Zone"

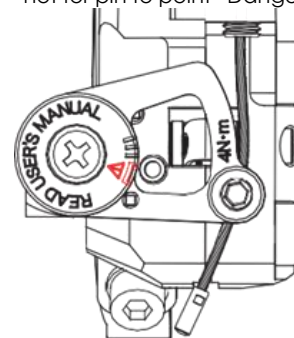

6. Maintenance

6-1. Replacing the brake pads

If the thickness of the brake pads becomes less than 1mm, it is recommended to replace the pads.

If the thickness of the brake pads becomes 0.5mm or less, be sure to replace the brake pads.

Follow the procedure below to replace the left and right pads at the same time.

Replace your brake pad, if it becomes less than 1mm thickness.

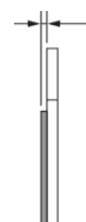

Replacement Procedure

1. Widen the clearance between pads and the rotor.

Before removing the pads, turn left the pad adjustment screws to increase spaces between the rotor and pads.

2. Remove the wheel from the frame.

3. Use a 2.5mm hex key to remove mounting screws for brake pads.

4. Remove the pad. The pad can be easily removed by pressing it from the top with a hex key (see ☆ below).

5. Install new pads (see. ① - ③).

6. Install the wheel on the frame.

7. Adjust the clearance of the pads.

See reference to "5-1 Adjusting the brake pad clearance".

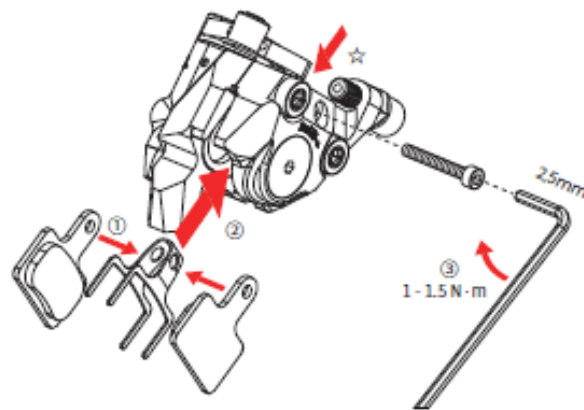

⚠ CAUTION:

Do not reuse the brake pad mounting screws.

Be careful not to get any oil or grease on the rotor or pads.

When replacing the pads, wipe off any brake debris or other dirt from the caliper itself.

When replacing with new brake pads, the brakes will be less effective until they fit in.

Repeat testing brakes from a safe speed in a safe place and start using the brake pads only after the brakes have been applied and the brakes are fully effective.

Due to individual differences in brake pads, some of them may not fit into the caliper due to their large width. If this is the case, you can use a file or similar tool to shave off a little of the width on both sides.

7. Daily Inspection before Riding

Before riding, be sure to check the following topics. If any error is found, adjust, replace, or contact your dealer or mail to GROWTAC (winfo@growthac.com). We will reply to you within 3 business days.

- ✓ The front and rear brakes should work properly.
- ✓ The brake lever has the correct amount of pull.
- ✓ There should be no fraying or cracking of the outer casing or inner cable.
- ✓ The thickness of the brake pads must be 0.5 mm or more.
- ✓ The pin must not enter the Danger Zone when the brake lever is depressed.