

EQUAL MECHANICAL DISC BRAKE CALIPER (FLAT MOUNT) DEALERS MANUAL

Important Notice

The dealer's manual is intended for people with specialized knowledge such as bicycle safety mechanics and bicycle technicians. Do not disassemble the product by referring to the dealer's manual if you do not have specialized knowledge. Do not disassemble the product without referring to the dealer manual. If you have any questions about the contents of this manual, please contact the dealer where you purchased the product or GROWTAC(wininfo@growthac.com). If you have any questions about the information in this manual, do not attempt any work. Please also read the EQUAL Mechanical Disc Brake Caliper (Flat Mount) User Manual. Do not disassemble or modify the product in any way that is not described in the dealer manual.

Warnings and Cautions

[WARNING]

When disassembling and assembling the product, follow the dealer manual. When assembling the product, it is recommended to use genuine EQUAL brake pads and screws.

Recommended assembly grease: SHIMANO Premium Grease

Please guide your customer on the following points

The brake calipers and rotors become extremely hot during use. Do not touch them until they have cooled down sufficiently, or you may be burned.

Do not allow grease or other oil to get on the rotor or brake pads.

If grease or oil gets on the rotor or brake pads, the brakes will not work and it is very dangerous.

Before riding, be sure to check that the thickness of the brake pads is at least 0.5 mm. If the thickness of the brake pads is more than 0.5mm, the brakes may not work properly.

If the pads are worn out, replace them with new ones referring to "6-1 Replacing the brake pads" in the user manual.

Standard brake pads: EQUAL disc brake pads DBR-PADA01(Shimano road compatible).

If the brake pads are worn out, adjust the clearance by referring to "5-1 Adjusting the brake pad clearance" in the user manual.

Before riding the bicycle, make sure that the brake cable is not frayed. If there are any loose ends, the brake cable may break and the brakes may fail to work.

If the front brake is applied too hard, the front wheel may lock, causing the bicycle to fall forward and cause serious injury.

The braking distance becomes longer in rainy weather. In wet condition, the braking distance is longer, so reduce speed and brake earlier.

If you brake suddenly when the road surface is wet, the tires may slip and you may fall over.

Make sure that the pin does not enter the danger zone of the swing arm when the brake is applied. If the pin enters the "Danger Zone", replace the brake pads or adjust the clearance.

Make sure that the brake pad mounting screws are properly tightened.

[Cautions]

Please instruct your customers on the following

When the brake pads or rotors are replaced with new ones, the brakes will be less effective until they are acclimated.

Please test it quite a few times in a safe place and in safe speed.

When the brake is applied, a braking sound may be heard.

If you have any questions about installation or adjustment, please contact us(wininfo@growthac.com).

1. Exploded Drawing

*For parts information not listed here, please refer to the user manual.

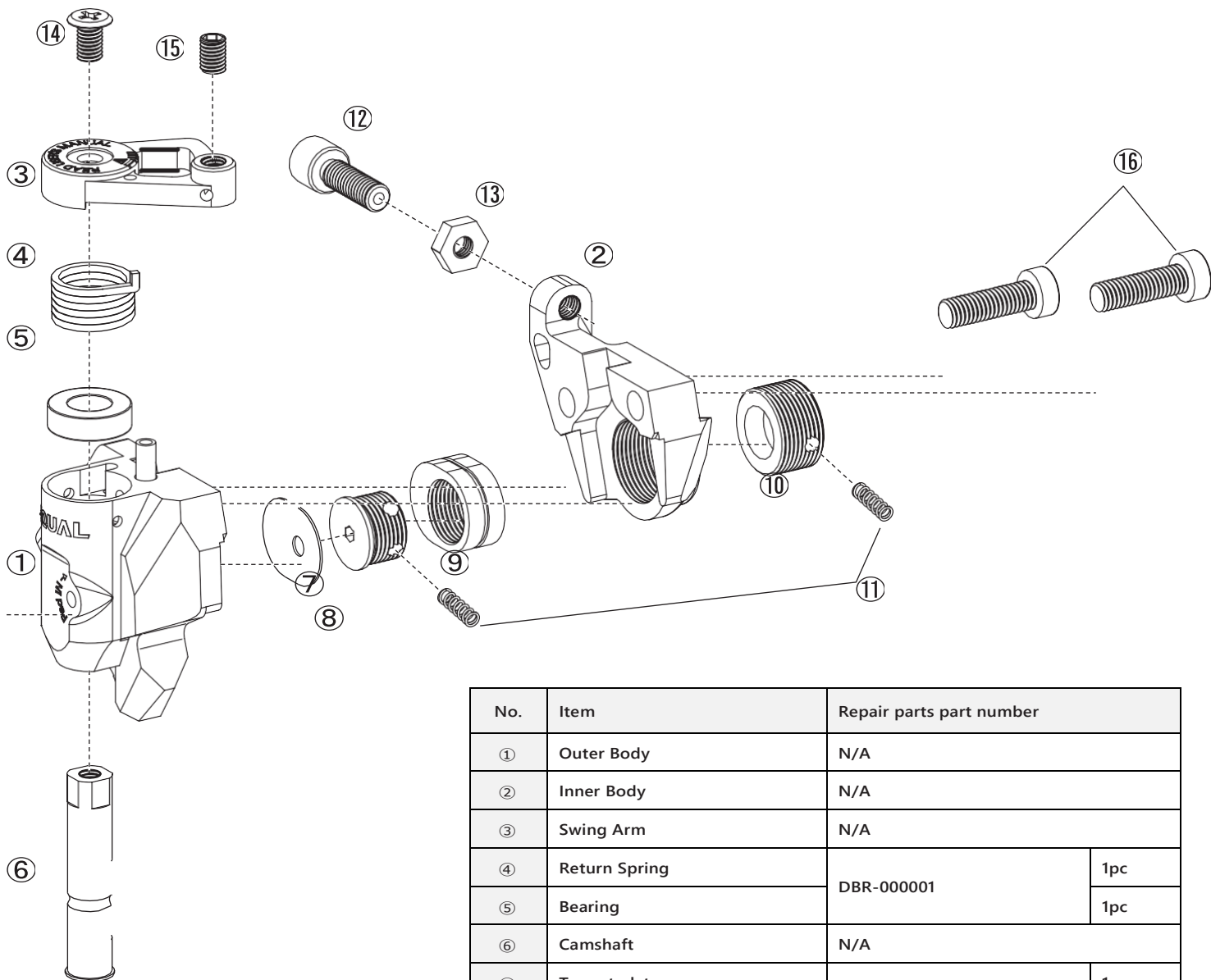

No.	Item	Repair parts part number	
①	Outer Body	N/A	
②	Inner Body	N/A	
③	Swing Arm	N/A	
④	Return Spring	DBR-000001	1pc
⑤	Bearing		1pc
⑥	Camshaft	N/A	
⑦	Tappet plate	DBR-000002	1pc
⑧	Outer pad adjustment screw		1pc
⑨	Piston		1pc
⑩	Inner pad adjustment screw	N/A	
⑪	Springs	DBR-000003	6pcs
⑫	Brake-leverage adjustment bolt	DBR-000004	1pc
⑬	Brake-leverage adjustment nut		1pc
⑭	Swing arm fixing screw	DBR-000005	1pc
⑮	Inner cable fixing bolt		1pc
⑯	Caliper coupling bolt		1pc

*5) Bearings are made of stainless steel.
If bearings other than stainless steel are used, rust will occur.

2. Maintenance

2-1. Situations in which maintenance is recommended

It is recommended to perform maintenance in the following cases.

- ✓ When the piston does not return properly.
- ✓ When the usage distance exceeds 20,000 km.

2-2. Maintenance

Grease the pistons, camshafts, and tappet plates.

Check the condition of the tappet plate (replace if necessary).

2-3 Tools needed for Maintenance

Hex key 2.5mm/3mm

Assembly grease(Recommended: SHIMANO Premium Grease)

2-4 Maintenance Procedure

1. Remove the wheel from the bicycle.
2. Remove the brake pad mounting screw and remove the brake pad (2.5mm Hex key).
3. Clean the brake pad and pad retaining spring using a mild detergent.
4. Wipe off the brake dust inside the caliper.
5. Turn the outer pad adjustment screw to the left until it stops turning (3mm Hex key)
6. Turn the inner pad adjustment screw to the left and remove it from the inner body (3mm Hex key)
[Note] The inner pad adjustment screw has a spring built in. The spring may pop out when removing it.
7. Insert the 3mm hex key into the outer pad adjustment screw and push it as it is to remove the piston.
Note: The outer pad adjustment screw does not require maintenance.
When removing the outer pad adjustment screw from the piston, the spring may pop out.
8. Wipe off any old grease from the piston surface.
9. Remove the tappet plate from the outer body.
[Caution] It may come off at the same time as the piston.
10. Wipe off any old grease from the tappet plate.
11. Apply enough grease to the camshaft.
12. Apply grease to both sides of the tappet plate.
13. Install the tappet plate
[Note] The tappet plate has a specific direction. The tappet plate must be oriented so that the hole in the tappet plate is an extension of the pad adjustment hole on the outer body.
[Caution] If the tappet plate has a groove where it comes in contact with the camshaft and is caught by a fingernail, it must be replaced. When installing, use a new one or turn it over for installation.
14. Apply a thin layer of grease to the light blue area(refer to Figure 1) on the side of the piston and fill the grooves with grease.
15. Install the piston
[Note] The piston has a specific orientation. The piston must be oriented so that the hex hole of the piston is on the extension of the pad adjustment hole on the outer body.
For the orientation, refer to "1. Part Names and Exploded View".
[Note] The pistons are made with high precision, so if they are even slightly askew, they will not fit. Do not try to insert the piston by hitting it with a tool, etc., but carefully align it.
[Note] When installing the piston, if grease sticks to the inside of the caliper, wipe it off carefully.
16. Install the inner pad adjustment screw (3mm Hex key)
Insert the spring into the inner pad adjustment screw and turn it in until the spring is hidden by the inner body.
17. Install the brake pads
Install the brake pads and pad retaining spring in combination.
18. Install the wheel on the bicycle
19. Adjust the brake pad clearance
Adjust the clearance by referring to "5-1 Adjusting the brake pad clearance" in the user manual.

Figure 1

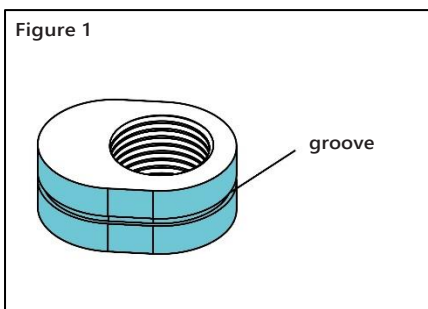

3. Overhaul

3-1. Situations where overhaul is recommended

When the following symptoms occur, overhauling may solve the problem.
If the movement of the swing arm is slow (jerky).

Please note

For overhauling, it is necessary to disassemble the brake caliper.

The caliper coupling bolt (Torx T30) is fixed with a very high torque.

When disassembling or reassembling, please observe the following precautions.

When disassembling or reassembling the brake caliper, take the following precautions.

Do not apply force to the brake-leverage adjustment bolt. Applying force to it during operation may result in damage.

[Tips] When disassembling and reassembling the caliper, it is recommended to keep the caliper attached to the bike for stable operation.

3-2. Overhaul contents

In addition to the maintenance items, the following items should be performed.

Grease up the camshaft and bearings.

Check the condition of the bearings (replace if necessary).

3-3. Tools required for overhaul

Phillips screwdriver #2

Hex key 2.5mm/3mm/4mm

Torx (hexarobular) wrench T30

Assembly grease(Recommended: SHIMANO Premium Grease)

Medium-strength screw locking adhesive (such as LOCTITE 243)

3-4. Overhaul Procedure

1. Remove the wheel from the bicycle.
2. Remove the brake pad mounting screw and remove the brake pads (2.5mm hex key).
3. Clean the brake pad and pad retaining spring using a mild detergent.
4. Remove the brake caliper from the bicycle.
[Tips] When removing the caliper coupling bolt, it may be easier to do so with the brake caliper installed on the bicycle.
5. Remove the caliper coupling bolt (Torx T30)
Please refer to [CAUTION] in "3-1.
6. Wipe off the brake dust inside the caliper.
7. Remove the piston and tappet plate referring to "2-4 Maintenance "Procedure 5-10.
8. Remove the swing arm mounting screw (Phillips screwdriver #2).
9. Remove the return spring, camshaft and bearing.
10. The parts to be cleaned are the pistons, tappet plates, return springs, camshafts, bearings, and bearing receptacles on the outer body.
11. Apply grease and install the camshaft, bearing and return spring (Figure 2).
 - (1) Apply grease to the camshaft (shown in blue) and install it in the outer body.
 - (2) Grease the inside of the outer body and the purple part of the camshaft.
 - (3) Insert the bearing.
 - (4) Apply grease to the inside of the return spring (red part) before inserting it.

[Note] The return spring has a specific direction. The long end is for the body and the short end is for the swing arm.
12. Install the swing arm while checking the following items.
Make sure that the return spring is properly inserted into the swing arm hole.
When looking at the camshaft through the piston hole, a flat surface should be visible.
[Caution] The return spring must be inserted while tightening. Please note that the back of the swing arm may be scratched.
13. Fixing the swing arm
Fix the swing arm with the swing arm fixing screw (Phillips screwdriver #2, specified torque 1Nm)
14. Assemble the piston part.
Grease and install the camshaft, tappet plate and piston referring to the section "2-4 Maintenance Procedure 11-
15. Assemble the outer body and inner body
Align the faces of the outer body and inner body and assemble them with the caliper coupling bolts (Torx T30, specified torque 12 Nm).
Apply medium-strength screw locking adhesive to the area 2~3mm from the end of the caliper coupling bolt.
If too much adhesive is applied, it may overflow into the caliper.
16. Installation on the bicycle
After installing the brake pads, install the caliper body on the bicycle according to the user manual.

